

OWNER'S MANUAL

Energy Storage System

Please read this manual carefully before installing your set and retain it for future reference.

MODEL

LG ESS Home 10 (D010KE1N211)

LG ESS Home 8 (D008KE1N211)



<https://www.lg.com/global/business/ess/business-resources/download>

Copyright © 2019-2022 LG Electronics Inc. All Rights Reserved.

Safety Information

1

Getting Started

IMPORTANT : THIS PRODUCT SHOULD NOT BE USED FOR ANY PURPOSE OTHER THAN THE PURPOSE DESCRIBED IN THIS INSTALLATION MANUAL.



WARNING

Indicates a potentially dangerous situation. Death or serious injury may result if appropriate precautions are not taken.

- There is high possibility of electric shock or serious burns due to the high voltages in power conditioning circuits.
- High voltages on AC and DC cables. Risk of death or serious injury due to electric shock.
- A potentially hazardous circumstance such as excessive heat or electrolyte mist may occur due to improper operating conditions, damage, misuse and/or abuse.
- This product have potential danger such as death or serious injury by fire, high voltages or explosion if appropriate precautions are not read or fully understood.
- Do not place flammable or potentially explosive objects near the product.
- Do not place any kind of objects on top of the product during operation.
- All works on the PV modules, power conditioning system, and battery system must be carried out by qualified personnel only.
- Electrical installations must be done in accordance with the local and national electrical safety standards.
- Wear rubber gloves and protective clothing (protective glasses and boots) when working on high voltage/high current systems such as PCS and battery systems.
- There is a risk of electric shock. Do not remove cover. There is no user serviceable parts inside. Refer servicing to qualified and accredited service technician.
- Electrical shock hazard. Do not touch uninsulated wires when the product cover is removed.
- In the event of fault, the system must not be restarted. Product maintenance of repairs must be performed by qualified personnel, or personnel from an authorized support center.
- If non LG Electronics batteries are connected to LG PCS, it will void warranty of the PCS and battery.



CAUTION

Indicates a situation where damage or injury could occur. If it is not avoided, minor injury and/or damage to property may result.

- This product is intended for residential use only and should not be used for commercial or industrial.
- Before testing electrical parts inside the system, it takes at least 10-minute standby period of time to complete discharging the system.
- This inverter includes an integrated residual current device (RCD). If an external residual current device (RCD) is used, a device of type A or B should be used, with a tripping current of 30 mA or higher.

- The contents included in this box are power conditioning system and its accessories, and the entire weight is very heavy. Serious injury may occur due to the heavy weight of the package with PCS and accessories. Therefore, special care must be taken in handling. Make sure to have at least two persons deliver and remove the package.
- Do not use the damaged, cracked or frayed electrical cables and connectors. Protect the electrical cables from physical or mechanical abuse, such as being twisted, kinked, pinched, closed in a door or walked upon. Periodically examine the electrical cables of your product, and if its appearance indicates damage or deterioration, discontinue use of this product, and have the cables replaced with an exact replacement part by a qualified personnel.
- Ensure that you connect the earth ground wire to prevent possible electric shock. Do not try to ground the product by connecting it to telephone wires, lightning rods or gas pipes.
- The product should not be exposed to water (dripping or splashing) and no objects filled with liquids, such as vases, should be placed on the product.
- To prevent fire or electric shock hazard, do not expose this production to rain or moisture.
- Do not block any ventilation openings. Ensure reliable operation of the product and protect it from over heating. The openings shall never be blocked by placing any object on this product.
- The temperature of metal enclosure may be high during operation.
- In order to avoid radio-interference, all accessories (like a energy meter) intended for connection to the product shall be suitable for use in residential, commercial and light-industry areas. Usually this requirement is fulfilled if the equipment complies with the class B limits of EN55022.
- The product must be disposed of according to local regulations.
- The electrical installation of this unit must only be performed by LGE service person or trained installer, qualified to install PCS.
- If the AC circuit breaker is turned off and the PCS is not operated for a long time, the battery may be overdischarged.
- Connect the DC+ and DC- cables to the correct DC+ and DC- terminals on the product.
- Danger of damaging the PCS by overload. Only connect the proper wire to DC terminal block. Refer to the installation wiring diagram for details.
- Do not step on the product or the product package. The product may be damaged.
- Do not dispose of batteries in a fire. The batteries may explode.
- Do not open or damage batteries. Released electrolyte is harmful to the skin and eyes. It may be toxic.
- A battery can present a risk of electrical shock and high short-circuit current. The following precautions should be observed when working on batteries.
 - a) Remove watches, ring, or other metal objects.
 - b) Use tools with insulated handles.
 - c) Wear rubber gloves, boots and glasses
 - d) Do not lay tools or metal parts on top of battery.
- Do not leave the ESS in the Fault standby state for a long time because of the battery discharge may occur during the long standby state.
- If the battery fault occurs immediately after starting PCS it means Battery failure. Check the battery SOC also voltage and fault information, and turn off the power of the ESS until service

action is taken.

- If the battery SOC is low the battery may charge from the grid for self-protection. (Emergency Charging) This function is to prevent shutdown of the ESS, deep discharge and failure of the Battery. An Emergency Charge is not an ESS fault.
- If the battery SoC is too low during the backup operation of a power outage, the PCS will only charge the battery from Solar PV. It means no power is supplied to the home load. Emergency Charging(backup) will charge the battery up to the backup SoC level that you set (30% by default). Emergency Charging(backup) is not an ESS fault.
- Install the PCS where the noise from the PCS will not inconvenience the neighbors. Failure to do so may result in conflict between neighbors.



NOTE

Indicates a risk of possible damage to the product.

- Before making connections, please make sure the PV array open circuit voltage is within 1000 V. Otherwise the product could be damaged.
- Never use any solvents, abrasives or corrosive materials to clean this product.
- Do not store on or place against any objects to the product. It may cause serious defects or malfunction.
- Before making a connection, make sure the PV switch on this product is switched off.
- This unit is designed to feed power to the public grid only. Do not connect this unit to an AC source or generator. Connecting the product to external devices could result in serious damage to your equipment.
- Servicing of batteries should be performed or supervised by LG service person or trained installer.
- The battery does not discharged when the load is under the certain level.
- This product can cause current with a DC component. Where a Residual Current-operated protective (RCD) or monitoring (RCM) device is used for protection in case of direct or indirect contact, only an RCD or RCM of Type A (or type B) is allowed on the supply side of this product.
- This product is designed to be installed indoor use only. Do not install this product outdoor.
- This document is for your reference only. Read the installation manual on the website below.
- Please check the following website for warranty policy.
<https://www.lg.com/global/business/ess/business-resources/download>

Table of Contents

Getting Started

Safety Information	2
Product Features.....	6
Name of Each Part	9
Front and Rear	9
LED Indications.....	10
Bottom	11

Operating

Connecting to a Mobile Device.....	12
Installing 'LG EnerVu Plus' App.....	12
Connect via Home WLAN	13
Connect directly to ESS	14
About Main Screen	17
ESS Status Menu	18
ESS Setting Menu	22
Language	22
Battery	22
Energy Device	23
Quick Install Guide	23
Open source	24
Application information	24
Installer Settings.....	24
ESS Information Menu	25
Energy Analysis	25
System Information	26

Using EnerVu

Using EnerVu system	27
Creating a New Account.....	27
Checking EnerVu Activation	30
Overview of my EnerVu page	31
Making a Statistical Graph.....	33
Making a Statistical Report.....	37
Transferring your system to other owner	38

Appendix

Maintenance.....	39
Cleaning the Product.....	39
Inspecting Regularly.....	39
Contact	39
Disposing the product.....	40
Specifications.....	41
Open Source Software Notice Information.....	43

1

2

3

4

Product Features

1

Getting Started

This product is intended to store direct current (DC) electricity generated from photovoltaic (PV) to the connected Lithium-Ion Battery, and convert direct current (DC) electricity from the connected battery and PV to alternating current (AC) electricity and feed this into the power grid. And, the battery supplies power to the household load in an emergency.

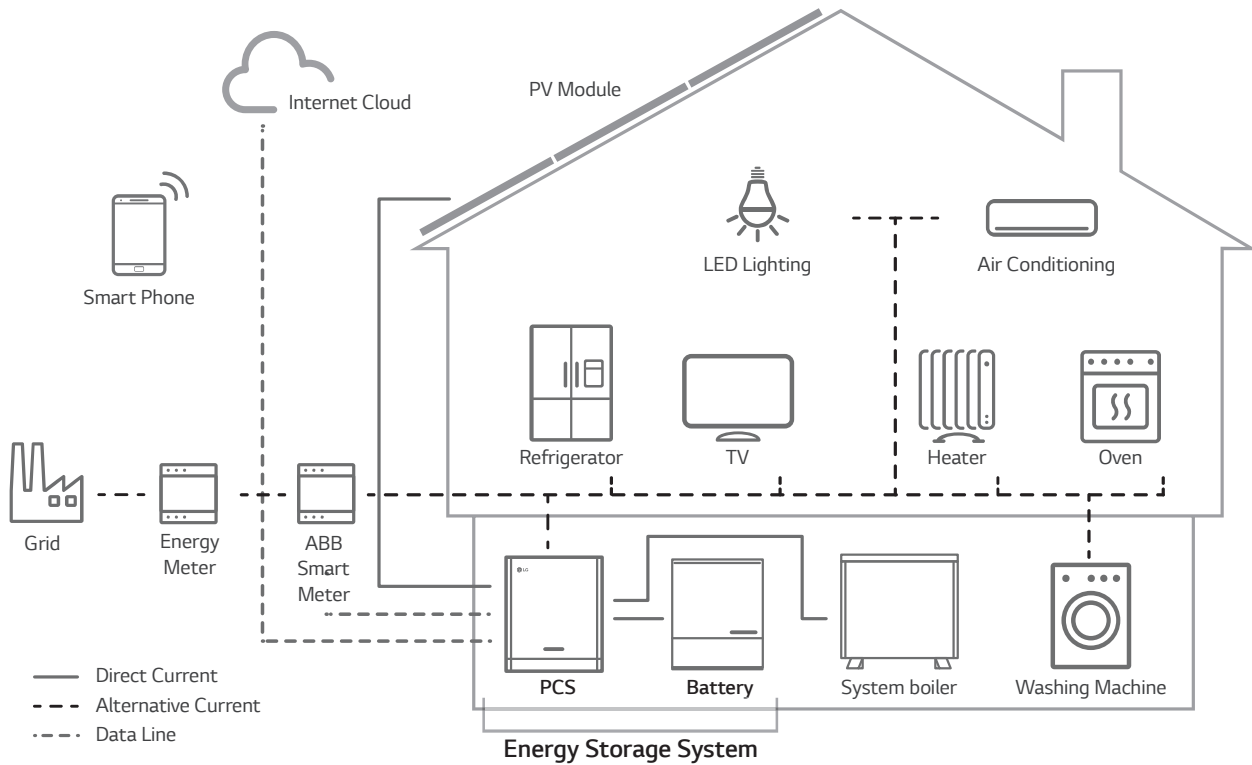

The electricity generated from a PV array can be stored to the connected battery or sold to energy supply companies.

- **DC-Coupled ESS**

LG ESS can achieve higher system efficiency due to simpler power conversion process.

- **Three-Phase Connection**

3-phase connection secures phase balancing.

- **Smart Management**

With built-in Smart PMS, it analyses PV generation and load consumption and implements to charge and discharge immediately. Also it monitors main system & battery conditions to maintain its stable condition always.

- **Web-monitoring Service**

Customers and installers can monitor their ESS with various devices such as PC, tablet or smart phones.

- **Backup Mode**

In an emergency, the battery supplies power to the household load.

Abbreviations on this manual

Abbreviation	Designation	Explanation
ESS	Energy Storage System	Inverter system that stores energy into a battery and uses it.
PCS	Power Conditioning System	A device intended to convert DC electricity generated from PV system to AC electricity and feed it to household appliances.
PV	Photovoltaic	Solar panel system that converts solar energy into direct current electricity
SOC	State of charge	Current state of a battery
BMS	Battery Management System	Electronic system that manages a rechargeable battery.
DC	Direct Current	-
AC	Alternating Current	-
DHCP	Dynamic Host Configuration Protocol	Standardized network protocol used on Internet Protocol (IP) networks for automatic distributing network configuration parameters, such as IP addresses for interfaces and services.
LAN	Local Area Network	Network that interconnects computers within a limited area.
IP	Internet Protocol	A set of rules for sending data across a network

Glossary

Terms	Explanation
Azimuth	In the Northern hemisphere, the azimuth angle indicates by how much degrees the module surface deviates from a full south aspect. In the southern hemisphere, it indicates the deviation from a full north aspect. The azimuth angle is counted with positive values within the range from south (0°) to west (90°) and it counted with negative values within the range from south (0°) to east (-90°).
Tilt angle	The tilt angle indicates by how much degrees the tilt of the module surface deviates from the horizontal.
PV module	The PV module refers to a panel designed to absorb the sun's rays as a source of energy for generating electricity.
PV array	Technical device for the conversion of solar energy into electrical energy. All serial and parallel installed and connected to PV modules of a PV system are referred to as a PV array.

Name of Each Part

Front and Rear

1

Getting Started

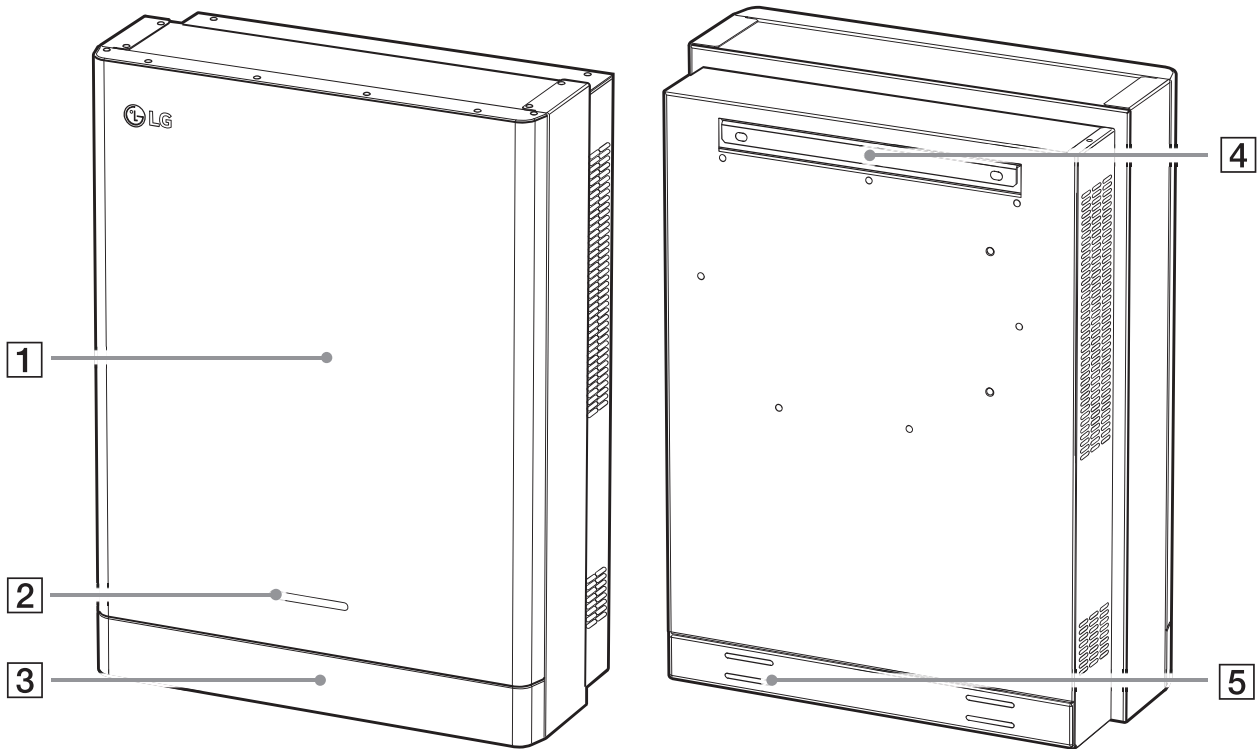

- 1** PCS body
- 2** LED Indications
- 3** Lower Cover

- 4** Bracket connected part
- 5** Screw holes for wall mounting

LED Indications

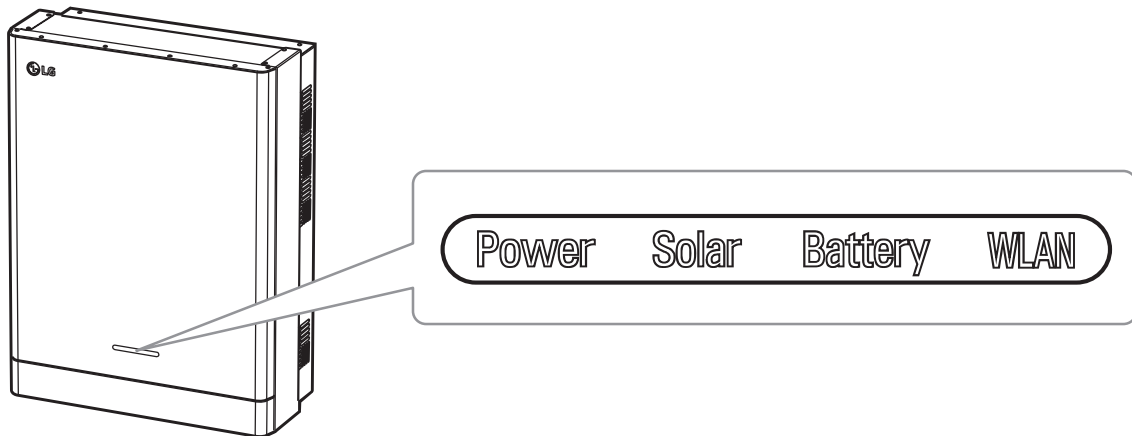

LED	Color	Description
Power	Off	Grid is not connected.
	White	Grid is connected.
	White (Blink)	PCS Fault
Solar	Off	Energy is not being generated.
	Green	Energy is being generated.
	White (Blink)	PCS Fault
Battery	Off	Stand by
	Green	Battery is in charging
	Blue	Battery is in discharging
	Red (Blink)	Battery error
	White (Blink)	PCS Fault
WLAN	Off	Unplugged WLAN dongle
	Green	Network connected
	Blue	WLAN network connected
	Red (Blink)	Network disconnected

Bottom

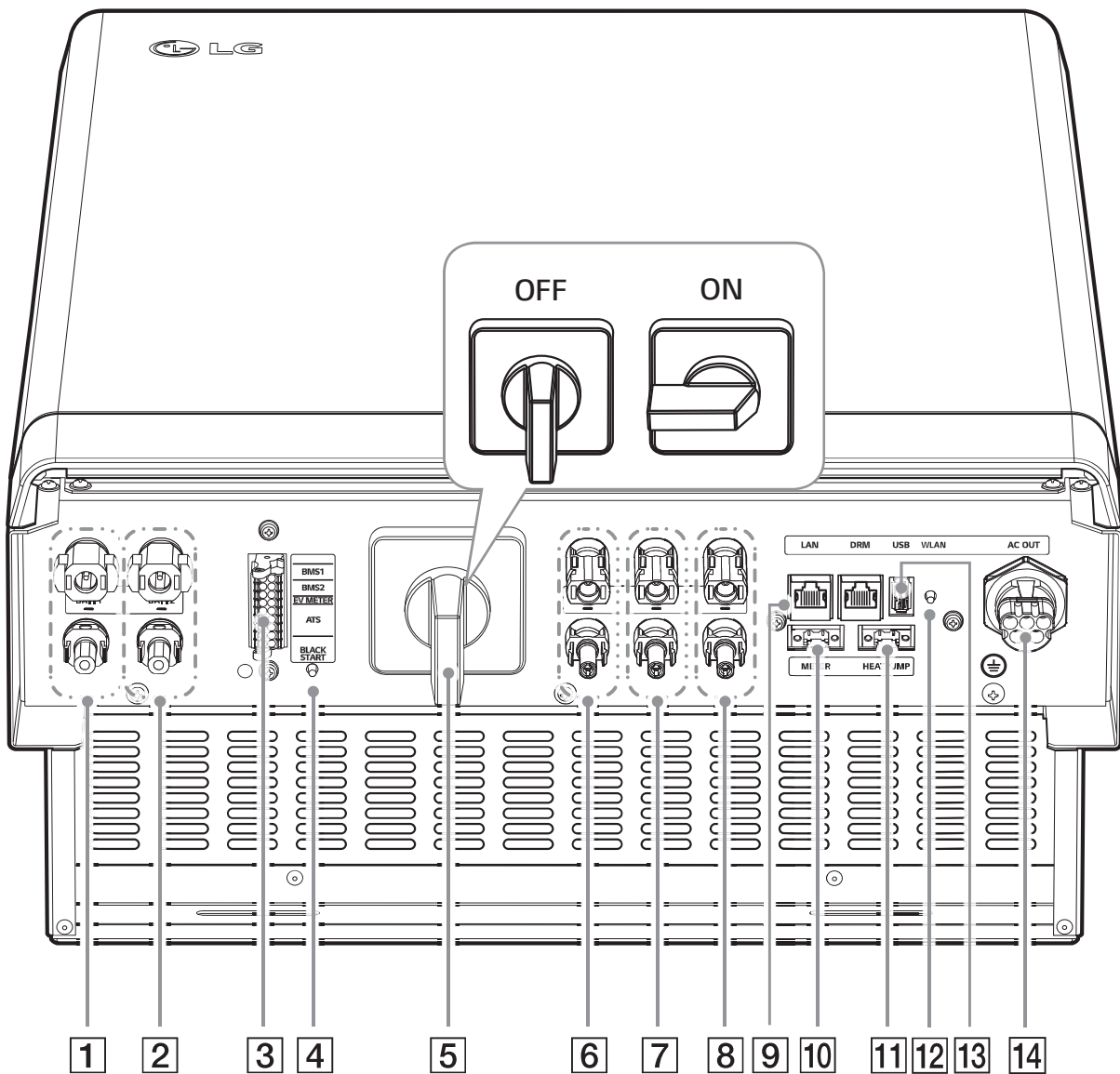

- | | | | |
|----------|-------------------------------|-----------|-----------------------------|
| 1 | Battery DC cable connectors 1 | 9 | Ethernet port |
| 2 | Battery DC cable connectors 2 | 10 | WLAN dangle port (USB type) |
| 3 | Communication terminals | 11 | Meter connector |
| 4 | Black start button | 12 | Heat pump connector |
| 5 | PV switch (DC Disconnect) | 13 | Wireless connection button |
| 6 | PV1(+ and -) connectors | 14 | AC grid cable connector |
| 7 | PV2 (+ and -) connectors | | |
| 8 | PV3 (+ and -) connectors | | |

Connecting to a Mobile Device

To connect the system to a mobile device, the LG EnerVu Plus mobile application must be installed on your mobile device. Search and download 'LG EnerVu Plus' application from Apple App store or Google Play store.

To connect to the system directly, the WLAN dongle must be connected to the system. Make sure that the supplied WLAN dongle is connected to the system.

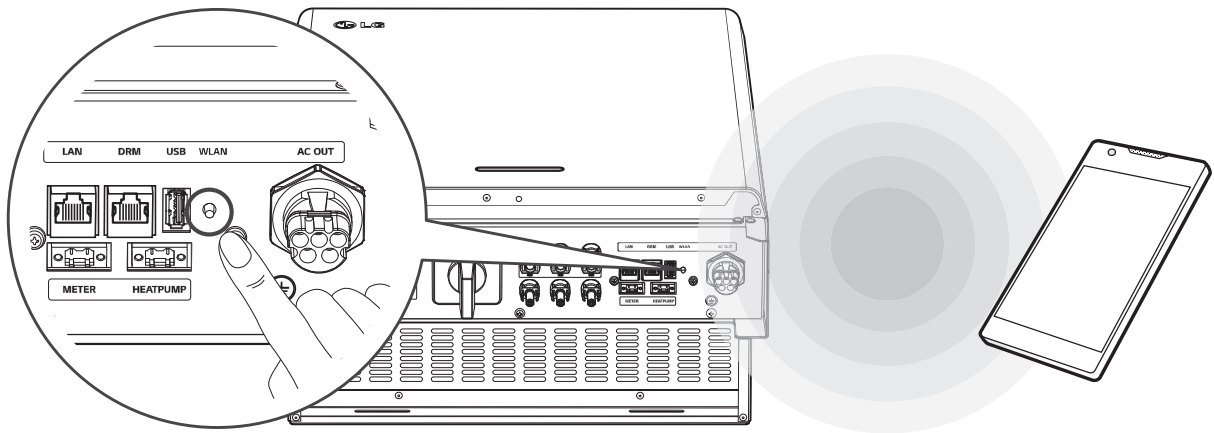

Installing 'LG EnerVu Plus' App

Download 'LG EnerVu Plus' on the Apple App Store or Google Play Store.

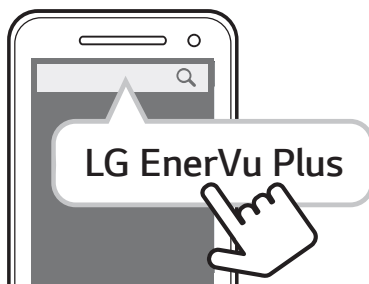

OR



iOS

NOTE

- Depending on the device, 'LG EnerVu Plus' app may not work.
- LG EnerVu Plus app will be available in version of the software as follow;
 - Android O/S : Lollipop (5.0) or later
 - iOS O/S : iPhone 6 (9.0) or later

Connect via Home WLAN

Preparation

- To connect the mobile device with the system via home network, the system must be connected to your home network. Check the [Network] setting menu on the system.
- Note the SSID of your home network.

1



Run 'LG EnerVu Plus' app on your mobile device.

2



Tap [Connect via Home WLAN] in the connection method selection screen.

3

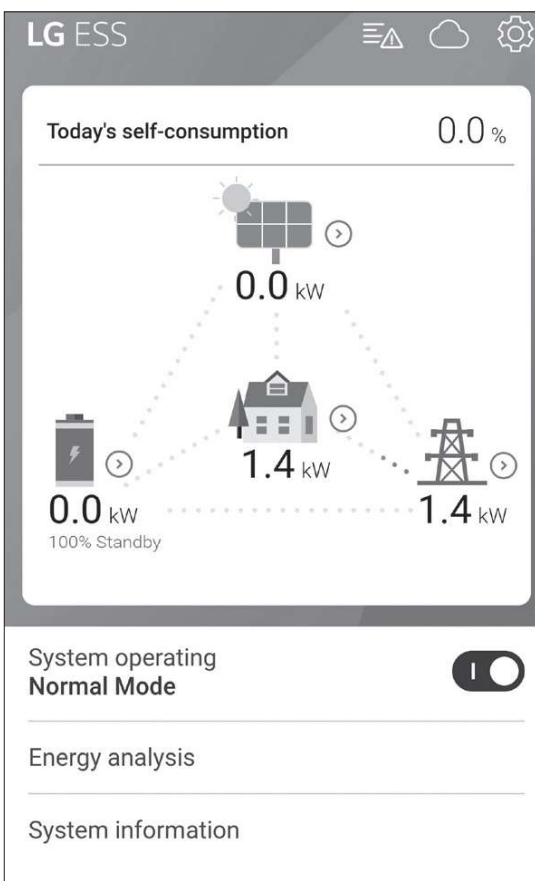

The connection will automatically be proceeded and main screen appears when the connection is successful.

4

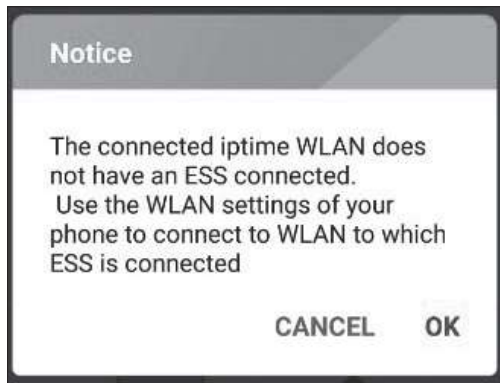

If the connection fails, a pop-up message appears on the screen.

Tap [OK] to move to the WLAN selection menu of the mobile device.

Select the SSID of your home network.

2

Operating

Connect directly to ESS

1



Run 'LG EnerVu Plus' app on your mobile device.

2

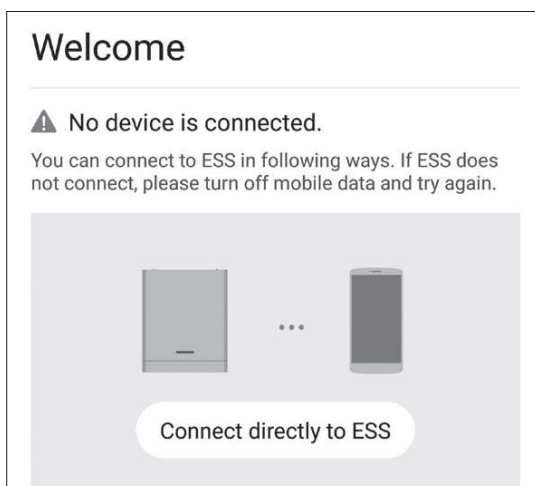

If it is the first time to connect to the system, connection method selection screen appears.

Tap [Connect directly to ESS] option.

3

Connect directly to ESS

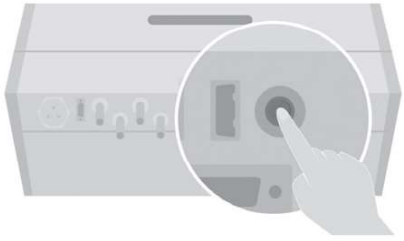

Push the WLAN button on bottom of ESS, and go to the menu Settings > WLAN and select ESS to connect. ESS WLAN password is 'WLAN Password' on right side of ESS device.

CANCEL OK

Press and hold the wireless connection button on the system until [WLAN] LED is lights in blue.

On your mobile device, tap [OK] to go to the next step.

NOTE

If the connection has not been made for 5 minutes, the [WLAN] LED lights green and the WLAN signal is disabled.

4

Connect directly to ESS

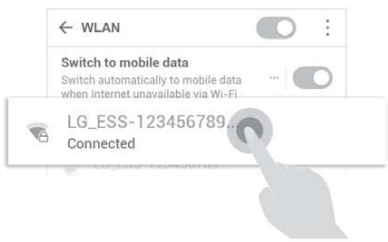

Push the WLAN button on bottom of ESS, and go to the menu Settings > WLAN and select ESS to connect. ESS WLAN password is 'WLAN Password' on right side of ESS device.

CANCEL OK

Read the guidance and tap [OK] to display WLAN selection screen.

Select the SSID which starts with 'LGE_ESS'. The password input screen appears.

NOTE

The last 2 characters of the SSID are the same as the last 2 characters of the system registration number.

Example :
 SSID (LGE_ESS-**5E**)
 Registration No. (LGE-ESS-DE1710BKRH0068**5E**)

5

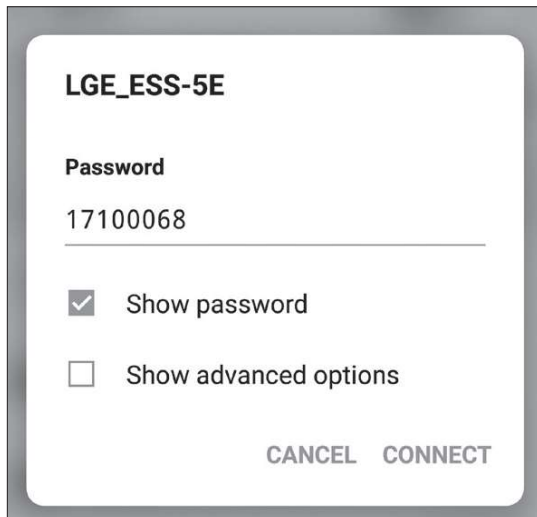

Input WLAN password in the password field to connect to the system.

The WLAN password is 8 digit numbers. Find the 'WLAN password' printed in the label outside of the PCS.

NOTE

If the connection failed, try after turning off the mobile data option on your mobile device.

Android : If the connection is successful, main screen appears as shown in the figure.

iOS : If the connection is successful, run [LG EnerVu Plus] app to display the main screen as shown in the figure.

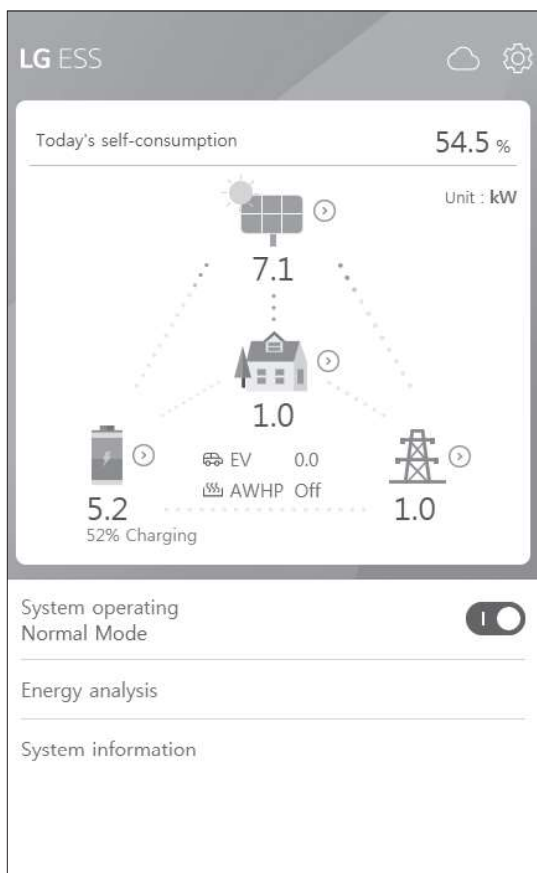

About Main Screen

The main screen displays and indicates current ESS status in the ESS status menu area. And you can check the several settings and information in the ESS setting menu and ESS Information menu areas.

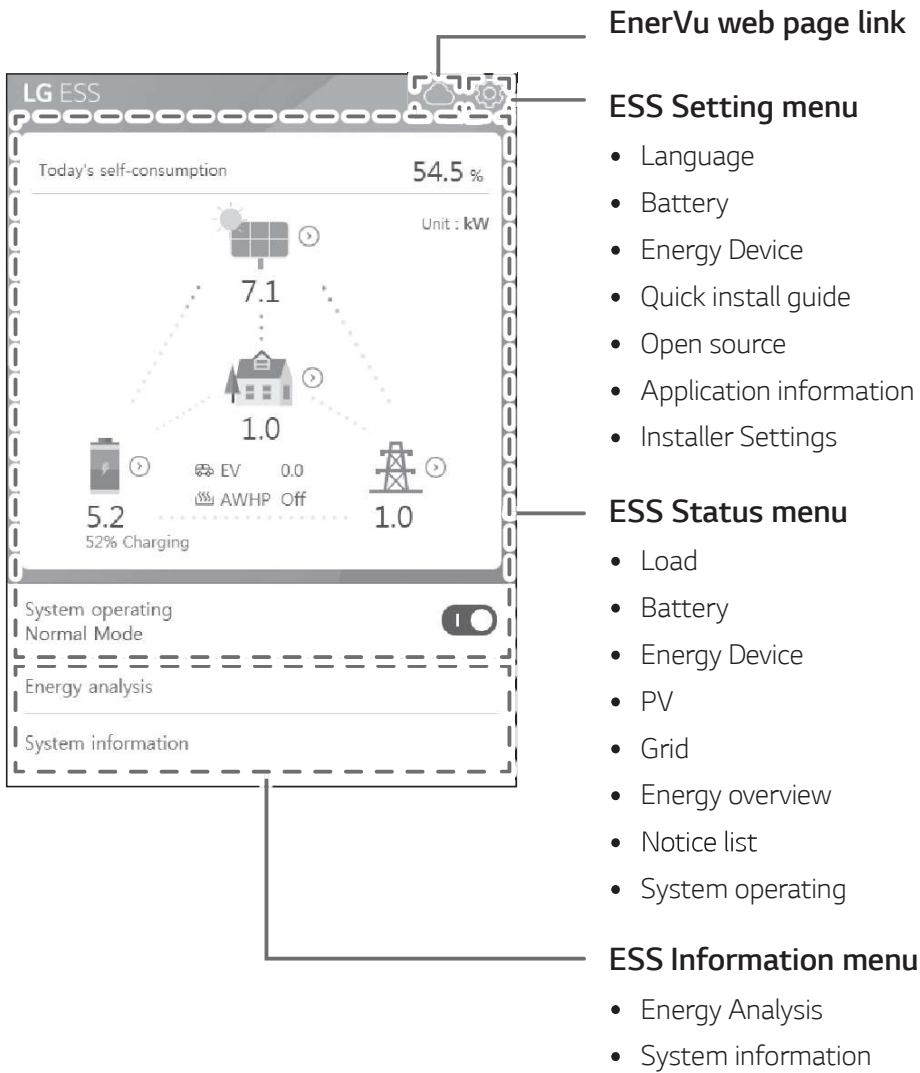

ESS Status Menu

The main screen displays and indicates current ESS status briefly. When you select an area indicated above, it displays detailed information.

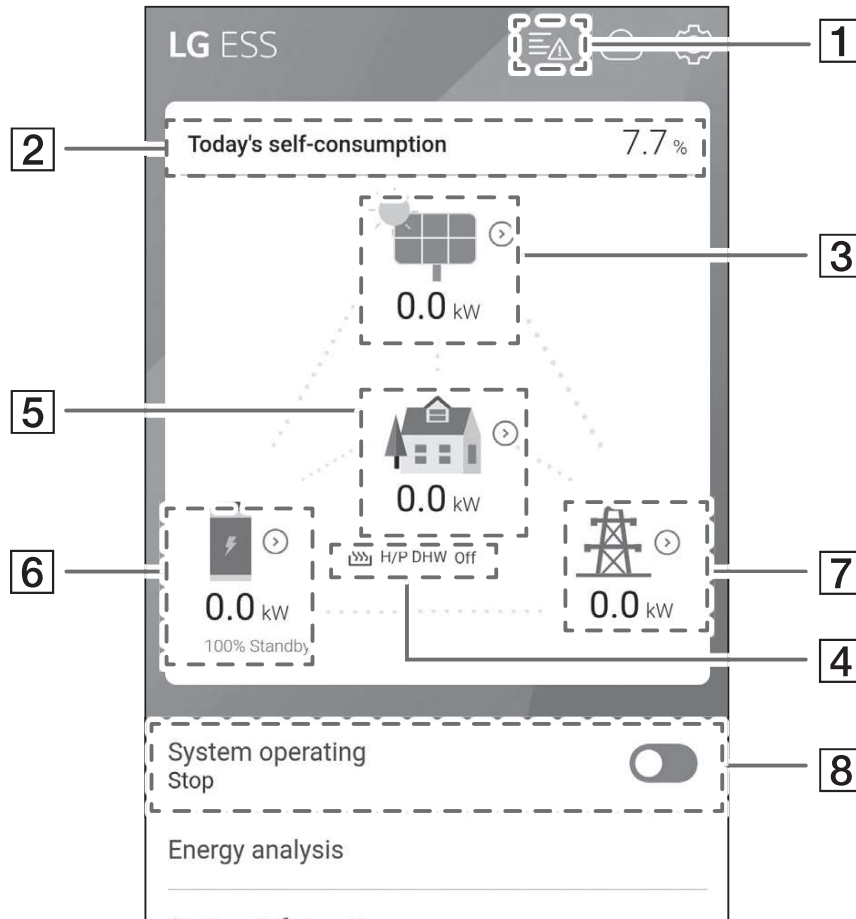

NOTE

- The displayed values are not exact values. The values may differ from actual values.
- Please turn on the AP again, if there is a problem at connection with AP.

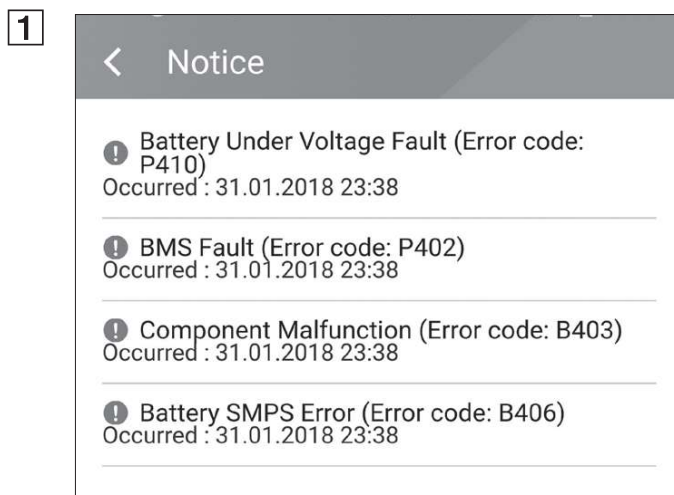

Displays a notice list of system status. When there is an error occurred, error code, time and date are displayed on the list. Refer to installation manual for more information of messages.

2

Energy Overview	
Today's self-consumption rate	54.5 %
This month's CO2 reduction	2.4 kg
Generation	
Today	0.9 kWh
This month	3.3 kWh
Feed-in	
Today	0.4 kWh
This month	1.7 kWh
PCS	
Feed in limitation	100 %
Status	Running

Displays the [Energy Overview] information on the screen.

Today's self-consumption rate : Displays rate of the consumed energy amount from ESS today.

This month's CO2 reduction : Displays monthly amount of CO2 reduction.

Generation: Displays generated energy information.

Feed-in : Displays consumed energy information.

PCS : Displays PCS information.

3

PV	
Brand	LGE-SOLAR
System Capacity	13.5kWp
DC Voltage	395V/390V/401V
DC Power	4490W/4641W/4361W
DC Current	11A/12A/11A
Today's generation	3.9 kWh
This month's generation	6.3 kWh

Displays generating status of the connected PV briefly.

The status values are the sum of PV1, PV2 and PV3.

Brand : PV Manufacturer (Default : LGE)

System Capacity : PV capability

DC Voltage : Current PV voltage

DC Power : Current PV power

DC Current : Current PV electric current

Today's generation: Generated PV energy today.

- 4 After the heat pump setup is completed, you can check the heat pump status on the Home screen.

Description of each state is as follows.

- None : AWHP setting is disabled or not connected.
- H/P DHW On : ESS make increase the desired temperature of AWHP.
- H/P DHW Off : AWHP retains a original desired temperature

NOTE

If PV system generate surplus power, Heat up the water in the heat pump and raise the Self consumption.

5

Load	
Load Power	0.1 kW
Today	
Total consumption	2.0 kWh
From PV	0.0 kWh
From Battery	0.0 kWh
From Grid	2.0 kWh
This Month	
Total consumption	2.0 kWh
From PV	0.0 kWh
From Battery	0.0 kWh

Displays detailed status of energy consumed in household.

Load Power : Current power consumed in household

Today

Total consumption : Amount of consumed energy today

From PV : Amount of energy from PV to household today

From Battery : Amount of energy from the battery to household today

From Grid : Amount of energy from the power grid to household today

This month

Total consumption : Amount of consumed energy this month

From PV : Amount of energy from PV to household this month

From Battery : Amount of energy from the battery to household this month

From Grid : Amount of energy from the power grid to household this month

6



Displays charging and discharging status of the battery briefly.

Battery Status : Charging/Discharging/ Standby

Battery SOC : Current SOC (state of charge) level

Winter Mode : Shows winter mode status.

DC Power : Current output power from battery

Today

Charging : Amount of charged energy to the battery today.

Discharging : Amount of discharged energy from the battery today

This month

Charging : Amount of charged energy to the battery in this month

Discharging : Amount of discharged energy from the battery in this month

7

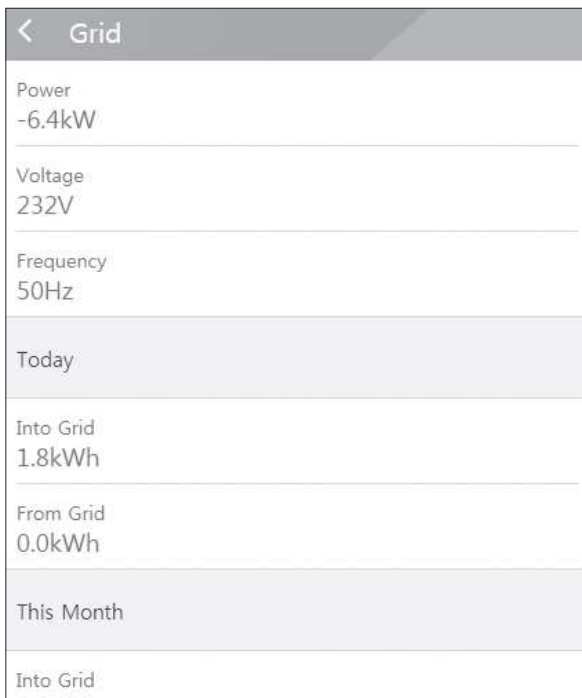

Displays current status of power grid.

Power: Current grid power

Voltage: Current grid voltage

Frequency : Current grid frequency

Today

Into Grid : Amount of sold energy today

From Grid : Amount of purchased energy today

This month

Into Grid : Amount of sold energy today and this month

From Grid : Amount of purchased energy this month

8



[System Operating]

Tap switch to start or stop system operation.

ESS Setting Menu

You can adjust general settings of the system. Select [main screen] > [⚙️] to display the [Setting] screen.

Language

Select [⚙️] > [Language] to display the language selection screen.



Select the desired language.

Battery

Select [⚙️] > [Battery] to display the battery setting screen.

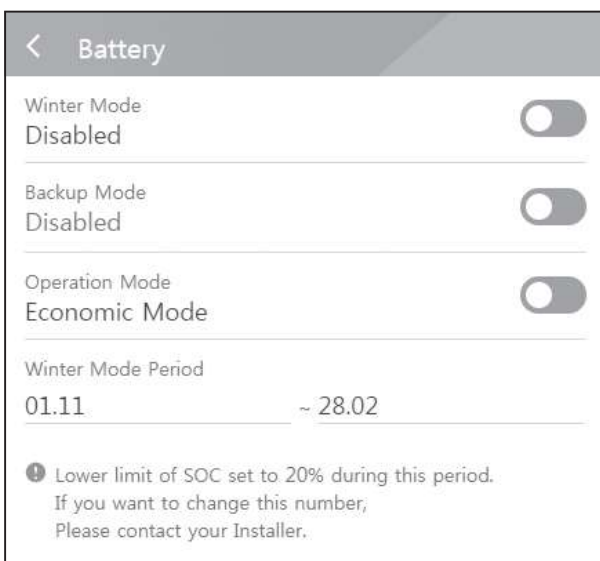

[Winter mode]

Tap this switch to select [Enable] or [Disable]. The minimum SOC level of winter mode can be changed by the installer only.

[Backup mode]

Tap this switch to select [Enable] or [Disable]. The minimum SOC level of Backup mode can be changed by the installer only.

[Operation Mode]

Tap this switch to select [Economic Mode] or [Fast Charge Mode]. You can change mode on your own.

Economic Mode : Make Feed- in more and make more efficiency to System.

Fast Charge Mode : Make fast charge to battery First.

[Winter Mode Period]

Tap current value to display the setting menu. You can change the period

1. Select the currently selected value. Period setting menu is displayed.
2. Adjust [Month] and [Day] using **V** or **Λ**.
3. Select [APPLY] to complete the setting.

Energy Device

Select [⚙️] > [Energy Device] to display the Energy Device screen.

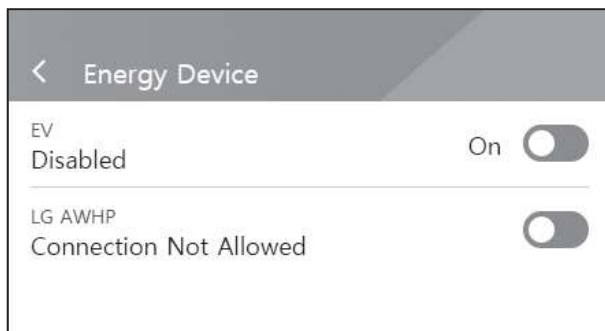

[EV]

Tap this switch to select [On] or [Off].

When 'EV Meter Enable' not setting, Error Popup occurred.

Set the option [On] to enable EV monitoring.

[AWHP]

Tap this switch to select [On] or [Off].

If its status is "Connection Available," wait until it becomes "Connected." If it is not connected to the end, check heat pump connection is connected properly.

The status description of the energy device is as follows.

- Connection Not Allowed : AWHP setting is disabled
- Connection Available : AWHP setting is enabled and is not connected
- Connected : AWHP setting is enabled and is connected

Quick Install Guide

Select [⚙️] > [Quick install guide] to display the install guidance screen.

You can check the brief installation instruction on the [Quick install Guide] screen.

Open source

You can check the open source information of the application and the system.

Select [⚙️] > [Open source] to display the open source notice screen.

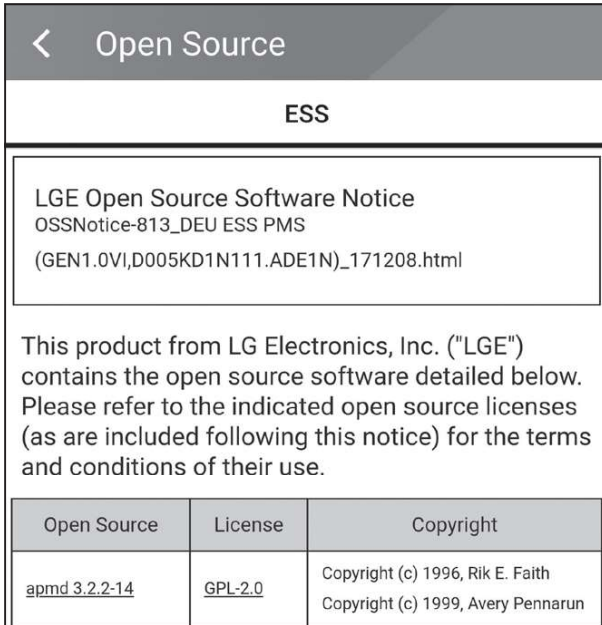

To obtain the source code under GPL, LGPL, MPL, and other open source licenses, that is contained in this product, please visit <http://opensource.lge.com>.

In addition to the source code, all referred license terms,

warranty disclaimers and copyright notices are available for download. LG Electronics will also provide open source code to you on CD-ROM for a charge covering the cost of performing such distribution (such as the cost of media, shipping, and handling) upon email request to opensource@lge.com. This offer is valid for three(3) years from the date on which you purchased the product.

Application information

Select [⚙️] > [Application information] to display the application information screen.

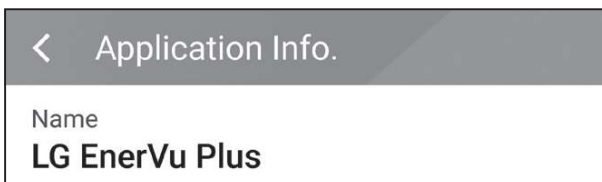

You can check the information of this application such as application name, application package name and application version.

Installer Settings

The system needs various system settings by installer when installing. Users are not allowed to enter [Installer Settings] menu. Try not to enter the menu. It may cause serious malfunction on the system, if user changes settings on the [Installer Settings] menu.

ESS Information Menu

Energy Analysis

On [Energy Analysis], you can check the statistical information of this system. You can review the amount of energy generated, consumed, sold and purchased on this system. The statistical data of the day, week, month and year are supported.

PV Graph

Analyzes the energy generated and sold from PV within selected period and displays as a graph.

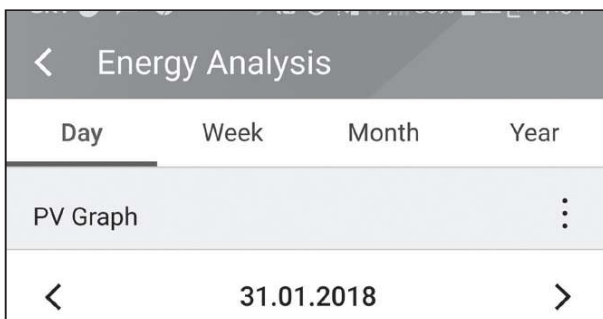

Select [PV Graph] on [Energy Analysis].

Generated energy is marked with green and sold energy is marked with purple on the line graph.

You can change the period by tapping [Day], [Week], [Month] and [Year].

< : Goes to previous [Day], [Week], [Month] or [Year].

> : Goes to next [Day], [Week], [Month] or [Year].

Battery Graph

Analyzes the energy charged and discharged on the battery within selected period and displays as a graph.

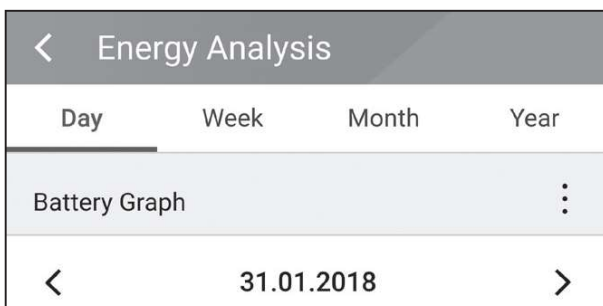

Select [Batt Graph] on [Energy Analysis].

Charged energy is marked with green, discharged energy is marked with purple, and current status of the battery is marked with yellow on the line graph.

You can change the period by tapping [Day], [Week], [Month] and [Year].

< : Goes to previous [Day], [Week], [Month] or [Year].

> : Goes to next [Day], [Week], [Month] or [Year].

Load Graph

Analyzes the energy consumed and purchased from grid within selected period and displays as a graph.

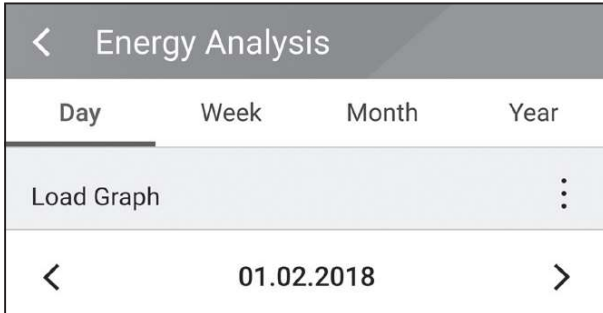

Select [Load Graph] on [Energy Analysis].

Consumed energy is marked with green, and purchased energy is marked with purple.

You can change the period by tapping [Day], [Week], [Month] and [Year].

< : Goes to previous [Day], [Week], [Month] or [Year].

> : Goes to next [Day], [Week], [Month] or [Year].

System Information



Displays system information of this ESS. You can check information on PCS, battery and network status. Scroll up or down to display next or previous information.

Using EnerVu system

When this product is connected to the internet, you can check variety of information such as system status, information, report using LG EnerVu web monitoring system.

NOTE

End users do not have to register in the EnerVu service. However, if the end user does not use this service, it is not possible to enable maintenance via remote service (such as firmware update) over the Internet.

Preparation

- An internet browser installed computer, tablet or mobile with internet access are needed to access LG ESS web monitoring system.
- This product must be connected to internet. Check [Network] setting menu on the system.

Creating a New Account

1



On your browser, visit LG EnerVu page at <http://enervu.lg-ess.com>.

Select [Owner].

2

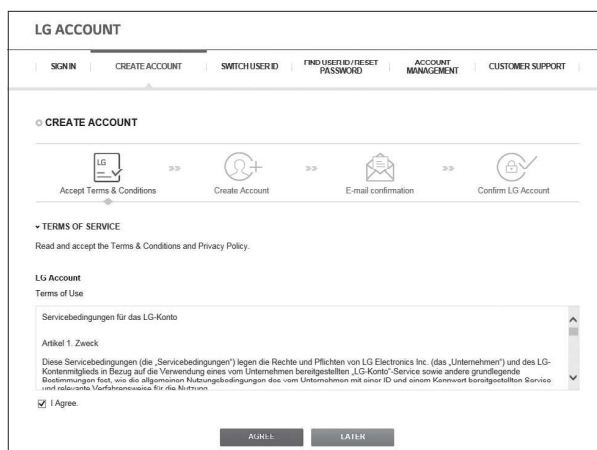

Select [Country] and select [Sign Up].

The [Accept Terms & Conditions] page appears. Read the Terms & Conditions and Privacy Policy carefully.

If you agree with every term and condition, click the [I Agree] check box and select [AGREE].

The account creation page appears.

3

Fill your mail address in [User ID] field and select [CHECK AVAILABILITY].

Fill in [Password], [Password confirm] and [Birthday] fields and select [CONFIRM]. The e-mail confirmation page appears.

3 Using EnerVu

A confirmation e-mail will be sent to your e-mail address. On your e-mail, select [CONFIRM] to complete the e-mail confirmation.

4

5

LG ACCOUNT

SIGN IN | CREATE ACCOUNT | SWITCH USER ID | FIND USER ID / RESET PASSWORD | ACCOUNT MANAGEMENT | CUSTOMER SUPPORT

CREATE ACCOUNT

Accept Terms & Conditions >> Create Account >> E-mail confirmation >> Confirm LG Account

EMAIL CONFIRMATION
LG Account created.

A confirmation e-mail has been sent to [hanspu15@naver.com].
Check your e-mail to verify and confirm your LG Account.
Any new accounts with Emails that are not verified within 48 hours of sign-up will be deleted.
Please check the spam folder of your email if you do not see the verification email in your inbox.

CONFIRM

On the account creation page, select [CONFIRM] to complete creating your account.

6

LG ACCOUNT

SIGN IN | CREATE ACCOUNT | SWITCH USER ID | FIND USER ID / RESET PASSWORD | ACCOUNT MANAGEMENT | CUSTOMER SUPPORT

CONFIRM LG ACCOUNT
LG Account creation complete.

Various services of LG Electronics can be accessed using a single LG Account.
Please sign in from the service you initially signed up.

SIGN IN

Select [SIGN IN] to go to the [SIGN IN WITH LG ACCOUNT] page.

Input your [User ID] and [Password] and select [SIGN IN].

LG ACCOUNT

SIGN IN | CREATE ACCOUNT | SWITCH USER ID | FIND USER ID / RESET PASSWORD | ACCOUNT MANAGEMENT | CUSTOMER SUPPORT

SIGN IN WITH LG ACCOUNT
Experience a variety of LG services with your LG Account.

User ID: [thid-bottle@daum.net] Password: [] SIGN IN

Remember my ID

SIGN IN WITH GOOGLE

SIGN IN WITH FACEBOOK

FIND USER ID RESET PASSWORD

7

LG ACCOUNT

Welcome, eecymnynm-4018@popmail.com SIGN OUT

ACCOUNT MANAGEMENT | CUSTOMER SUPPORT

SERVICE | NOTICE | FAQ

AVAILABLE LG ACCOUNT SERVICES
Various services of LG Electronics can be accessed using a single LG Account.

- LG SmartThinQ
- LG SmartWorld (Mobile)
- LG Developer
- LG SmartThinQ (old)
- LG Fitness
- LG EnerVu (Solar)
- LG Action Cam LTE Manager
- LG HomeChat for watch
- LG Rolling Bot
- LG Whisen
- IFTTT LG Smartphone Channel
- S-GAC TMS II
- Twice Speaker
- Pay Global Application
- LG Content Store (Smart TV)
- LG AirDrive
- LG Health
- Photovoltaic Energy Monitoring (Solar)
- Quick Help
- EVO Home IoT
- ARCH Service
- LG MusicFlow
- LG Health for watch
- GRAPHY
- Dee Revoles
- Kids Band Service
- LG SmartWorld for Watch

Available LG account services are displayed on the screen.

Checking EnerVu Activation

1

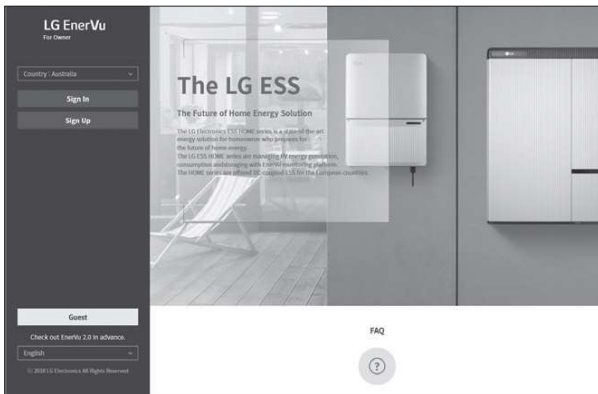

On your browser, visit LG EnerVu page at <http://enervu.lg-ess.com>.

Select [Owner] then [Sign In] page will appear. Check proper [Country] is selected and select [Sign In].

OR

On your mobile app, select [☁] to open the LG EnerVu page with a mobile browser.

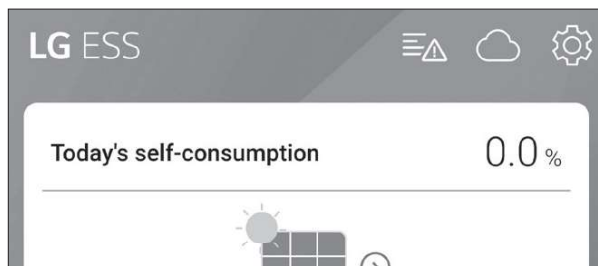

2



Input your [User ID] and [Password] and select [SIGN IN].

3

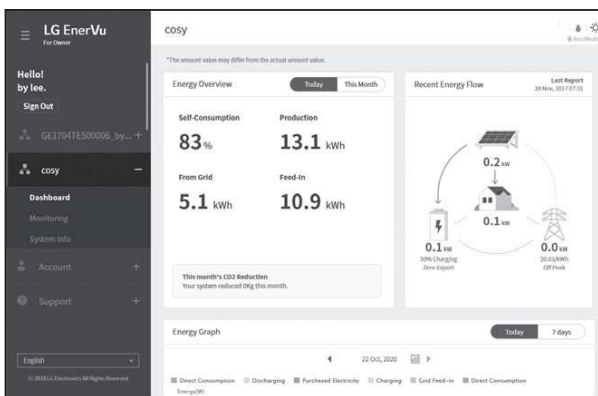

You can see the screen on the left when the registration and activation are completed.

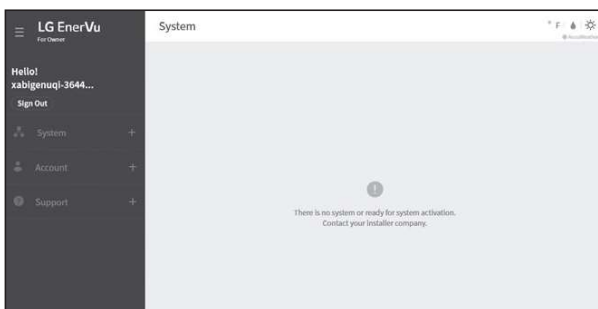

You can see the screen on the left when the registration is in incomplete status. In such case, contact the installer to activate your system.

Overview of my EnerVu page

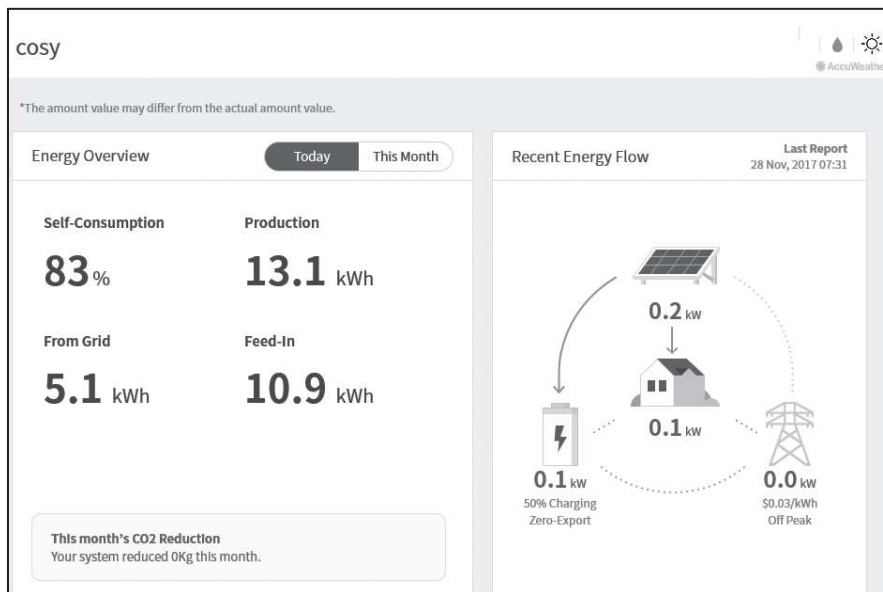

When you enter the main page of your EnerVu, you can find and check various information related to your system.

Weather

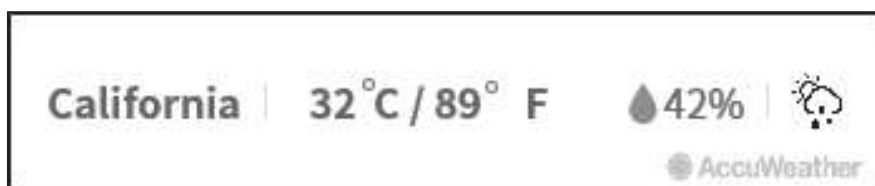

Displays the weather of the location the system has been installed.

System Overview

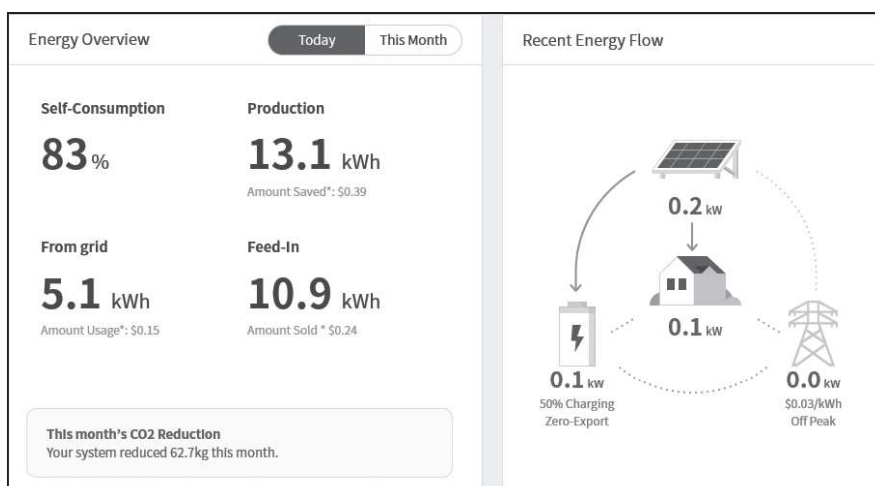

Displays the status of the system. This page provides you with system information such as current power generated from PV, power purchased from grid, power charged/discharged from the battery. ALL the information is renewed every 10 seconds.

Monitoring

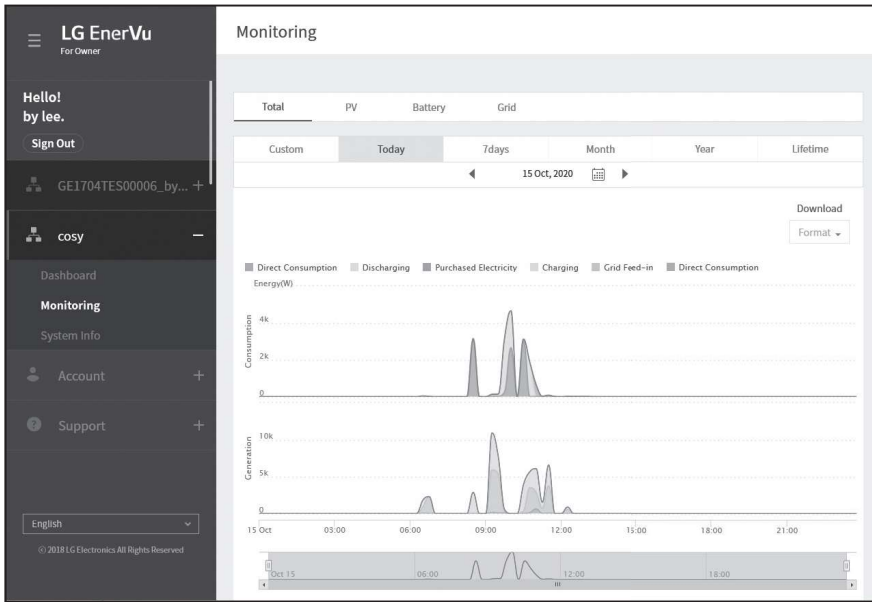

On this page, you can make a statistical graph of the energy analysis.

You can review the amount of energy generated, consumed, sold and purchased on the system.

The variety of statistical charts are supported on the page.

3

Using EnerVu

System Info

System Info			
cosy			
Site Address	LG ESS		
,, Germany	PCS Capacity	5.00 kW	
	Battery Capacity	6.40 kWh	
ESS GE1704TEST000389			
PMS S/W Ver.	PMS H/W Ver.	PCS S/W Ver.	PCS H/W Ver.
08.04.6005	Rev1.0	LGPCS.00.97.00.91	

Displays information on your system.

Report

Report

You can download or print the file by designating the report type and time period.

1. Report Type: Report
 2. Date: 22 Oct, 2020 - 22 Oct, 2020
 3. File Format: File

[Run Report](#)

In [Report] section under [System Info] menu, you can make a monthly or an yearly report of statistical data for energy management on your system.

Making a Statistical Graph

You can make a daily, monthly or an yearly graph of statistical data for energy management on your system.

Select [Custom], [Today], [7days], [Month], [Year] or [Lifetime] option to make a graph of statistical data.

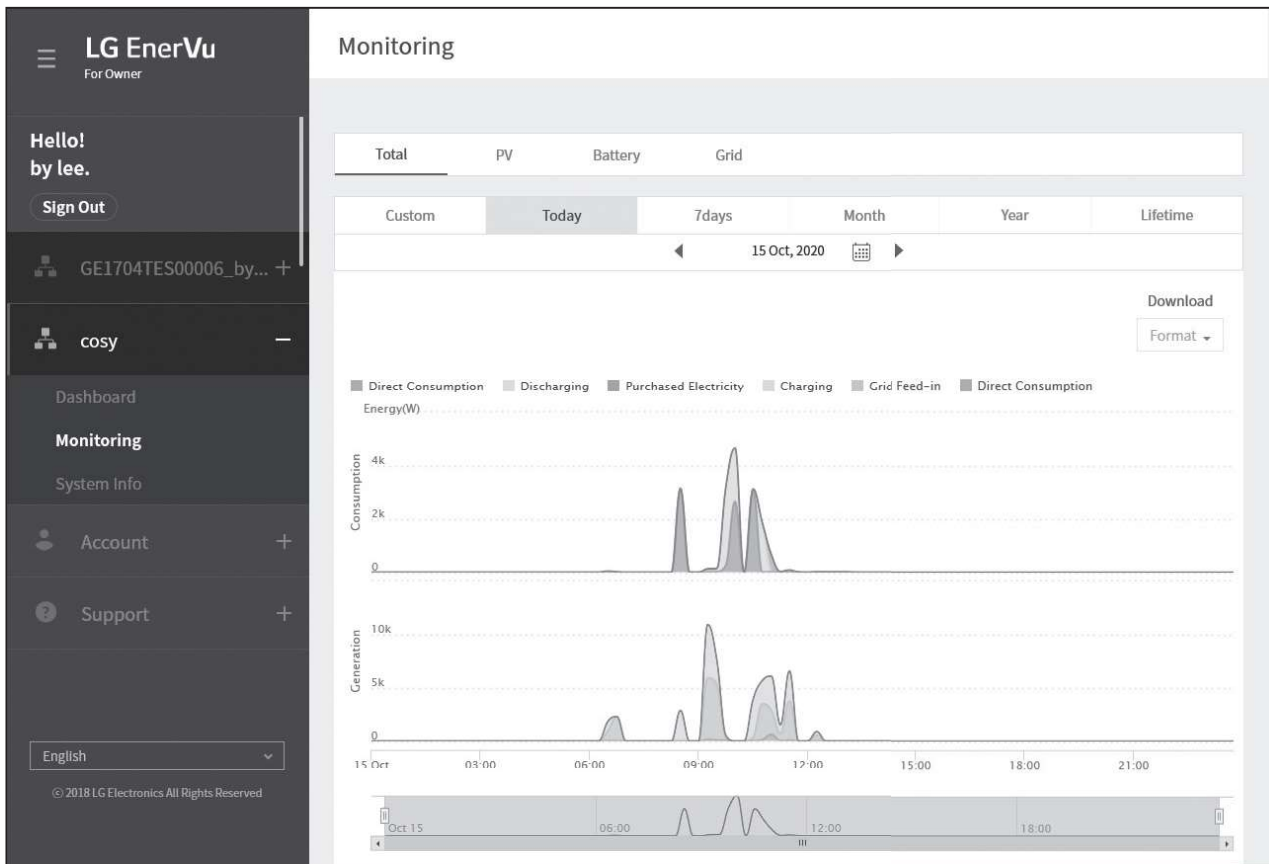

1. Select a tab on top of the screen.

Total	Makes an overall graph of statistical data.
PV	Makes a graph of statistical data on PV. (Generation and Grid feed-in)
Battery	Makes a graph of statistical data on ESS (Charging, Discharging and SOC)
Grid	Makes a graph of statistical data on household load. (Consumption and Purchase)

2. Select a duration option among [Custom], [Today], [7days], [Month], [Year] or [Lifetime].
3. Select a date, month or year to make a statistical graph.
After the selection, the graph will be displayed in a short time.

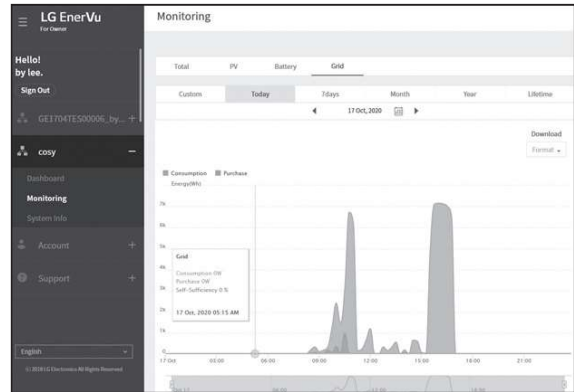
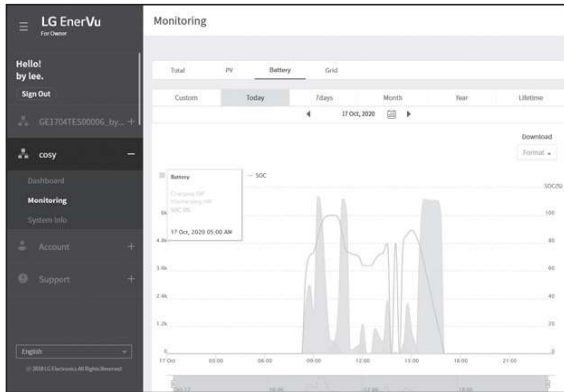
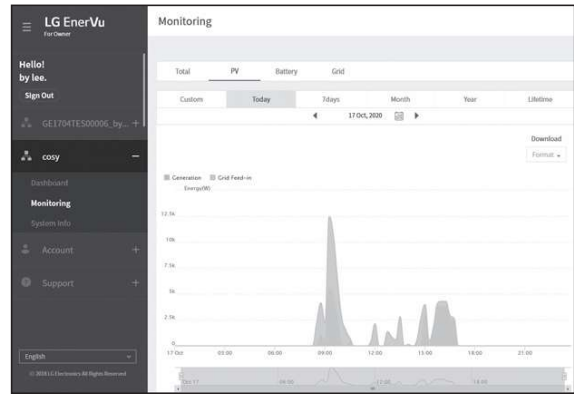
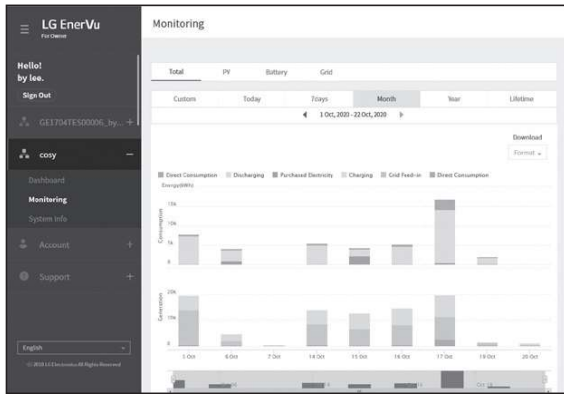

3
Using EnerVu

4. There are several options at the bottom of a graph, click each option to show or hide the statistical information on the graph.

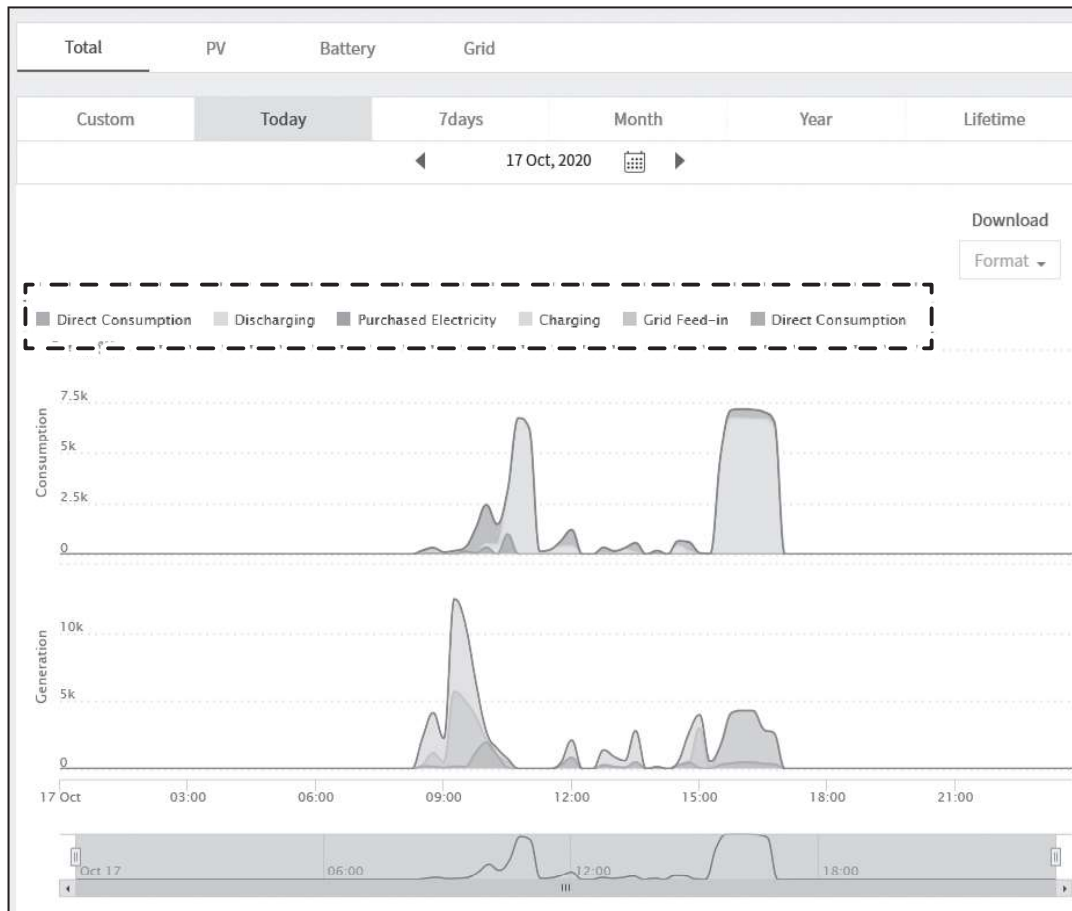

Available options differ depending on the graph. Refer to table described below for more information of graph options.

Tab	Graph	Options	Description
Total	CONSUMPTION	Direct Consumption	Amount of directly used energy from PV.
		Discharging	Amount of energy that used from the battery.
		Purchased electricity	Purchased energy through the power grid.
	GENERATION	Direct Consumption	Amount of directly used energy from PV
		Charging	Amount of energy that charged to the battery.
		Grid feed-in	Amount of sold energy to the power grid.

PV	Energy	Generation	Amount of generated energy from PV.
		Grid feed-in	Amount of sold energy to the power grid.
Battery	Energy	Charging	Amount of energy that charged to the battery.
		Discharging	Amount of used energy from the battery.
		SOC	State of charge
Grid	Energy	Consumption	Amount of used energy from ESS.
		Purchase	Amount of purchased energy from the power grid.

5. Select proper [Format] under [Download] to print a graph or download as an image file.

Making a Statistical Report

You can make a monthly or an yearly report of daily, monthly or yearly report of statistical data for energy on your system.

Report

You can download or print the file by designating the report type and time period.

1. Report Type 2. Date 3. File Format

Report  22 Oct, 2020 - 22 Oct, 2020 File Run Report

1. Select a report option among possible options below.
 - Total Energy (15-minute)
 - Energy Balance (Daily)
 - Battery (Daily)
 - Grid (Daily)
 - Total Energy (Daily)
 - Energy Balance (Yearly)
 - Battery (Yearly)
 - Grid (Yearly)
 - Total Energy (Monthly)
 - Energy Production (Daily)
 - Energy Production (Yearly)
2. Select desired [Date].
3. Select desired [File Format], excel or PDF.
4. Select [Run Report]. A statistical report will be displayed.

LG EnerVu

TOTAL Report

ESS QA Field test On : 22 Oct, 2020

Fasanenweg 5 Nürnberg,
BY 90489. Germany 

This report summarizes daily Production, Consumption, Feed-In, From Grid, Charging, Discharging. From 12 Oct, 2020 to 17 Oct, 2020.

Date	Production (kWh)	Consumption (kWh)	Feed-In (kWh)	From Grid (kWh)	Charging (kWh)	Discharging (kWh)
12 Oct, 2020	0.00	0.00	0.00	0.00	0.00	0.00
13 Oct						

Select  to print the statistical data.

Transferring your system to other owner

You can transfer your system to other owner. Once your system is transferred, the system can not be monitored with your account.

Preparation

- Note the email address of recipient.
- The email address of recipient must be registered as a LG member. If the recipient is still not a LG member, an automatic email requesting to become a member will be sent to the recipient.

1

On your browser, visit LG EnerVu page at <http://enervu.lg-ess.com>.

Select [Sign Up] and then select your nationality in the pop-up window. The [SIGN IN WITH LG ACCOUNT] page appears.

Enter your [User ID] and [Password] then select [SIGN IN] to enter the EnerVu web monitoring system.

2

Select [Assign to New Owner] at the bottom of screen after select [System Info] menu. Then the system transfer popup will appear on the screen.

3

Enter the email address of the recipient in the [Email] field and select [Check].

If the recipient is not a LG account service member, you can send mail to guide joining to LG account service by selecting [Invite].

4

If recipient is already a member of LG account service, [Done] button will appear after select [Check].

Finally, system transfer will be completed when select [Done] button.

Maintenance

Cleaning the Product

Wipe off the outside of the product with a soft towel with lukewarm water and wipe it with a clean hand towel so that dirt will not occur when using a neutral detergent. When cleaning the outside of the product, do not brush it with a rough brush, toothpaste, or flammable materials. Do not use cleaning agents containing flammable substances.

- It may cause discoloration of the product or damage to the product.
- Flammable substances : Alcohol (Ethanol, Methanol, Isopropyl alcohol, Isobutyl alcohol, etc.), Thinner, Benzene, Flammable liquid, Abrasive etc.)

Wiping with strong pressure may damage the surface. Do not leave rubber or plastic products in contact with the product for a long period of time.

When cleaning the air duct, shut off all the systems including PCS, PV module, battery, AC circuit breaker. After that, clean the filter with soft brush.

Inspecting Regularly

It is recommended to check the operating status and connection status once a year. It should be done by technician or authorized people. Contact authorized dealer or where you purchased.

Contact

If you have technical problems or questions, contact installation company or LG Electronics.

1. Installation Company

Address :

Tel :

2. Customer Service

LG Electronics ESS | Solar Service

E-Service Haberkorn GmbH

Augustenhöhe 7

06493 Harzgerode

Tel : Germany: 0049 (0)39484 / 976 380

Austria: 0043 (0)720 / 11 66 01

Switzerland: 0041 (0)44 / 505 11 42

Belgium, Netherlands, Luxembourg:
0031 20 / 456 1660

E-Mail : lge@e-service48.de

3. LG Electronics Contact

LG Electronics Deutschland GmbH

Alfred-Herrhausen-Allee 3-5
65760 Eschborn

Tel. : + 0049 18 06 807 020

E-Mail: b2b.service@lge.de

LG Electronics Benelux

Krijgsman 1, 1186 DM, Amstelveen,
The Netherlands

Tel: +0031 (0)20 456 3100

E-Mail: b2b.service@lge.de

Disposing the product

When the product reached to the end of its service life or defect beyond repair, dispose the product according to the disposal regulations for electronic waste in your area. Disposing the product must be carried out by qualified personnel only. Contact authorized dealer or where you purchased.



1. This crossed-out wheeled bin symbol indicates that waste electrical and electronic products (WEEE) should be disposed of separately from the municipal waste stream.
2. Old electrical products can contain hazardous substances so correct disposal of your old appliance will help prevent potential negative consequences for the environment and human health.
Your old appliance may contain reusable parts that could be used to repair other products, and other valuable materials that can be recycled to conserve limited resources.
3. You can take your appliance either to the shop where you purchased the product, or contact your local government waste office for details of your nearest authorised WEEE collection point. For the most up to date information for your country please see www.lg.com/global/recycling

Removal of waste batteries and accumulators (Product with embedded battery ONLY)

In case this product contains a battery incorporated within the product which cannot be readily removed by end-users, LG recommends that only qualified professionals remove the battery, either for replacement or for recycling at the end of this product's working life. To prevent damage to the product, and for their own safety, users should not attempt to remove the battery and should contact LG Service Helpline, or other independent service providers for advice.

Removal of the battery will involve dismantling of the product case, disconnection of the electrical cables/contacts, and careful extraction of the battery cell using specialized tools. If you need the instructions for qualified professionals on how to remove the battery safely, please visit <http://www.lge.com/global/sustainability/environment/take-back-recycling>

Disposal of waste batteries/accumulators



1. This symbol may be combined with chemical symbols for mercury (Hg), cadmium (Cd) or lead (Pb) if the battery contains more than 0.0005% of mercury, 0.002% of cadmium or 0.004% of lead.
2. All batteries/accumulators should be disposed separately from the municipal waste stream via designated collection facilities appointed by the government or the local authorities.
3. The correct disposal of your old batteries/accumulators will help to prevent potential negative consequences for the environment, animal and human health.
4. For more detailed information about disposal of your old batteries/ accumulators, please contact your city office, waste disposal service or the shop where you purchased the product. (<http://www.lg.com/global/sustainability/environment/take-back-recycling/global-network-europe>)

Specifications

PV Input	LG ESS Home 8	LG ESS Home 10
Input Voltage Range	150 ~ 1,000 V _{DC}	
Max. DC Power (per channel)	12 kW (6 kW)	13.5 kW (7.5 kW)
Usable MPP Voltage Range	150 ~ 800 V	
Number of MPPT	3	
Number of String per MPPT	1	
Max. Input Current per MPPT	13 A	
Max. inverter backfeed current to the array	0 A	

AC Output	LG ESS Home 8	LG ESS Home 10
Rated Grid Voltage	3-NPE 400 V / 230 V	
AC Voltage Range	319 ~ 458 V / 184 ~ 264.5 V	
Frequency(Range)	50Hz (47.5 Hz ~ 51.5 Hz)	
Rated Output Power	8 kVA	10 kVA
Rated Output current	11.5 A	14.4 A
THD / Power Factor	< 5 % / ± 0.8	
Inrush current (peak and duration)	70 Aac / 0.02 ms	
Max. output fault current	80 Aac / 20 ms	
Max. output overcurrent protection	55.6 A _{peak}	

Backup output	LG ESS Home 8	LG ESS Home 10
Maximum usable home load capacity in backup operation ¹⁾	Single Battery LGHB 7H	Single Battery LGHB 10H LGHBP 10H LGHBP 16H LGHBC 11H LGHBC 15H
		Dual Batteries LGHB 10H+10H LGHB 10H+7H LGHB 7H+7H LGHBP 10H+10H LGHBP 16H+16H LGHBC 11H+11H LGHBC 15H+15H
Total	3.5 kW	5 kW
Each phase	1.2 kW	1.7 kW
		2.3 kW

1) The capacity may decrease as the battery ages.

Battery	LGHB 7H	LGHB 10H	LGHBP 10H	LGHBP 16H
Battery Type	Lithium Polymer High Voltage			
Total Capacity	7.0 kWh	9.8 kWh	9.87 kWh	16.45 kWh
Usable Capacity	6.6 kWh ¹⁾	9.3 kWh ¹⁾	9.6 kWh ²⁾	16kWh ²⁾
Max. Charge/Discharge power (Single/Dual) ⁴⁾	3.5 kW / 7kW		5 kW / 7 kW	
Peak Power (Single/Dual)	5 kW / 10 kW for 5 sec.		7 kW / 10 kW for 10 sec.	
Rated output voltage	400 V			
Communication Interface	RS485			
Max. Charge/Discharge Current	8.5 A@420 V / 10 A@350 V		11.9 A@420 V / 14.3 A@350 V	
Voltage (nominal or range)	Charge : 400-450 V _{DC} / Discharge: 350-430 V _{DC}			

Battery	LGHBC 11H	LGHBC 15H
Battery Type	Lithium ion	
Total Capacity	11.9 kWh	15.8 kWh
Usable Capacity	10.7 kWh ³⁾	14.3 kWh ³⁾
Max. Charge/Discharge power (Single/Dual) ⁴⁾	Single: 4 kW / 5 kW Dual: 7 kW / 7 kW	5 kW / 7 kW
Peak Power (Single/Dual)	7 kW / 10 kW for 10 sec.	
Rated output voltage	305 V	407 V
Communication Interface	RS485	
Max. Charge/Discharge Current	14A@280V / 17.6A@289V	13.1A@373V / 14A@385V
Voltage (nominal or range)	Charge : 243-344 Vdc Discharge : 285-344 Vdc	Charge : 325-458 Vdc Discharge : 380-458 Vdc

- 1) Value for battery cell only (depth of discharge 95 %). Approximately 10 % of the battery usable capacity is used by system for battery protection. The capacity may decrease as the battery ages.
- 2) Value for battery cell only (depth of discharge 97.5 %). Approximately 10 % of the battery usable capacity is used by system for battery protection. The capacity may decrease as the battery ages.
- 3) Approximately 10 % of the battery usable capacity is used by system for battery protection. The capacity may decrease as the battery ages.
- 4) Charging and discharging may take longer depending on ambient temperature and SoC. The specified value relates to the consumption of the entire system. The available capacity to supply the loads depends on the operating behavior of the overall system, the protection against depth charging, the installation location, and the age of the LG ESS battery.

Efficiency (PCS)

Max. Efficiency (PV to Grid)	97.7 %
------------------------------	--------

General Data

Dimensions (W/H/D, mm)	450/599/210 (PCS), 746/688/206 (LGHB 7H), 746/903/206 (LGHB 10H), 504/816/295 (LGHBP 10H), 504/1086/295 (LGHBP 16H), 698/1073/205 (LGHBC 11H/15H)
Weight	34 kg (PCS) / 75 kg (LGHB 10H), 97 kg (LGHB 16H), 112 kg (LGHBP 10H), 160 kg (LGHBP 16H), 117 kg (LGHBC 11H), 142 kg (LGHBC 15H)
Operating temperature	0 °C to 40 °C (derating at 40-60 °C)

Energy Meter Compatibility	
ABB	B23 112-100, B23 212-100, B23 312-100

ATS (option)	
enwitec	Type 10013677, Type 10013678, Type 10013679

- An external ATS is required for stand alone mode.
- For LG Electronics' ATS Box, you can use enwitec.
- For installation and connection to the ESS, refer to the ATS Box manual.

Feature & function	
Noise emission (Typical)	< 40 dB
Cooling	Forced convection
Topology	Transformerless
Degree of protection	IP21
Max. permissible value of relative humidity (non-condensing)	85 % (Climate class 3K5)
Warranty (PCS)	10 years
Warranty (Battery) ¹⁾	10 years
Certification (PCS)	2014/53/EURED, IEC/EN62109-1/-2, EN61000 Series, EN55011, EN301, EN50549-1:2019, VDE-AR-N 4105, DIN VDE V 0124-100, TOR, C10/11, OVE-R25, RD1699, NTS2.0, UNE206007-1, UNE217001/2, TF3.3.1, AS4777.2
Class B Group 1 Product	Protection Class(Class I)
Pollution degree	2

1) Germany (DACH) : SOH 80%, other countries : SOH 60%

- The noise emission value is measured in a soundproof room and can vary depending on the environment.
- If you are installing in a place sensitive to noise, please consult the installer.
- Design and specifications are subject to change without notice.

Open Source Software Notice Information

To obtain the source code under GPL, LGPL, MPL, and other open source licenses, that is contained in this product, please visit <http://opensource.lge.com>. In addition to the source code, all referred license terms, warranty disclaimers and copyright notices are available for download. LG Electronics will also provide open source code to you on CD-ROM for a charge covering the cost of performing such distribution (such as the cost of media, shipping, and handling) upon email request to opensource@lge.com. This offer is valid for three (3) years from the date on which you purchased the product.

